

EN



Repair manual

Liquid pre-heaters

BINAR-5S BINAR-5S (diesel)
BINAR-5S-TM BINAR-5S-TM (diesel)
BINAR-5S-24-TM (diesel)

Contents

1	Main technical characteristics.....	3
2	Safety measures	4
3	Construction and description of the main units of the heater	4
4	Possible heater faults, their root causes, and troubleshooting methods	4
5	Purpose, repair, and replacement of pre-heater units.....	7
5.1	<i>Purpose, check, and replacement of the glow plug</i>	8
5.2	<i>Purpose, dismounting, and replacement of the flame detector</i>	9
5.3	<i>Purpose, dismounting, and replacement of the air blower</i>	11
5.4	<i>Purpose, dismounting, and replacement of the control unit</i>	12
5.5	<i>Purpose, dismounting, and replacement of the temperature sensors.....</i>	13
5.6	<i>Purpose, dismounting, and replacement of the combustion chamber.....</i>	14
5.7	<i>Purpose, dismounting, and replacement of the heat exchanger.....</i>	15
5.8	<i>Purpose, dismounting, and replacement of the fuel pump</i>	16
5.9	<i>Purpose, dismounting, and replacement of the electric motor and the pump.....</i>	17
5.10	<i>Purpose, dismounting, and replacement of the control panel.....</i>	18
5.11	<i>Unlocking the pre-heater</i>	18
6	Pre-heater check after installation.....	19
7	Manufacturer's warranty	19

Production
ADVERS LLC

Sales Departments
AUTOTERM LLC
Triekatas 4, Riga, Latvia,
LV-1026
+371 20110229
sales@autoterm-europe.com
www.autoterm-europe.com

Technical Support
AUTOTERM LLC
Triekatas 4, Riga, Latvia
LV-1026
+371 25529999
service@autoterm-europe.com

This repair manual (“RM”) is intended for use by the maintenance personnel for BINAR-5S hydronic pre-heaters (“pre-heaters”). This manual contains techniques for troubleshooting, as well as for determining whether various units and parts are in good condition or need to be replaced.

This manual also contains general technical specifications and descriptions of the units and their purpose as parts of the pre-heater, as well as tips for their maintenance and particular features of the various models.

The operating manual and the catalogue of parts and assemblies must be used alongside this manual during the repair of the pre-heater.

This repair manual may not include information about minor design alterations made by the manufacturer after the publication date of this RM.

1 Main technical characteristics

See Table 1 for the main technical characteristics of the pre-heater.

The technical characteristics include a $\pm 10\%$ tolerance and are specified for operation at the rated power supply voltage and air temperature of 20°C.

Table 1

Characteristic	Model		
	BINAR-5S BINAR-5S-TM	BINAR-5S (diesel) BINAR-5S-TM (diesel)	BINAR-5S-24-TM (diesel)
Heat capacity, kW	5±0.5		
Rated power voltage, V	12		24
Operating power voltage range, V	9.5–16		20...30
Fuel type	petrol (GOST R 51105)	diesel fuel (GOST 305)	
Fuel consumption (max.), l/h	0.7	0.62	
Heat transfer agent	antifreeze		
Electric power consumed, pump included, (max.), W	42		
Power consumed at startup (100 s), W	122		120
Ignition mode	manual or automatic		
Cycle time, min	20–120		
Pre-heater mass in full configuration, kg, max.	8		

2 Safety measures

- 2.1 Relevant workforce safety rules must be observed during the repair.
- 2.2 Failure to observe pre-heater operation instructions may cause fire.
- 2.3 A workplace must be equipped with fire-fighting means.
- 2.4 Do not refuel an operating pre-heater.
- 2.5 Do not operate the pre-heater with the fuel system poorly sealed.
- 2.6 Do not use the pre-heater within confined spaces and in poorly ventilated rooms.
- 2.7 Do not switch off power to the pre-heater before the purging cycle ends.
- 2.8 Where flame appears at the exhaust nozzle, turn the heater off and repair the fault after it stops.

3 Construction and description of the main units of the heater

- 3.1 The construction, main units and parts of the pre-heater are shown in the CPA (catalogue of parts and assemblies).
- 3.2 The electric circuit diagram is shown in the installation manual.

4 Possible heater faults, their root causes, and troubleshooting methods

A fault may occur during operation of the pre-heater. A fault may be diagnosed by a malfunction code indicated on the control panel, as described in Table 2.

There may be faults that are not identifiable via the control unit, such as loss of sealing in the heat exchanger (burning out) or loss of heat capacity due to fouling of the inner surface of the heat exchanger. The above faults may be diagnosed by visual inspection.

DO NOT OPERATE THE PRE-HEATER WITH A POORLY SEALED HEAT EXCHANGER.

During pre-heater operation, its separate units may fail to operate, and some of them may be replaced without removing the entire pre-heater from the vehicle. Such units include the fuel pump, the pump, or the control panel.

A PC (laptop) with a USB socket may be used for diagnosing the condition of the pre-heater units. To do so, connect the PC to the pre-heater in place of the control panel using the USB adapter (supplied separately). A configuration and installation manual for the USB adapter may be found at www.autoterm-europe.com

Table 2

Codes	Malfunction description	Cause of malfunction	Recommended troubleshooting methods
01	Overheating (upper temperature limit exceeded)	Temperature near one of the sensors exceeds 120°C	1. Check the entire liquid circuit for air blocks. 2. Check the pump (section 5.9). 3. Check the overheating sensor and the temperature sensor (section 5.5). 4. Check the antifreeze for suitability at current ambient temperatures
03	Temperature sensor 1 fault	Short or open circuit in the electric wiring	Replace the sensor assembly (section 5.5)
04	Temperature sensor 2 fault		
05	Flame detector fault	Short circuit to frame or open circuit in the detector wiring	Check the flame detector (section 5.2)
06	Control unit temperature sensor fault	The temperature sensor is faulty (located in the control unit, cannot be replaced)	Replace the control unit (section 5.4)
09	Glow plug fault	Short or open circuit, control unit fault	Check the glow plug (section 5.1). Check the control unit (section 5.4)
10	Air blower fault. Speed lower than rated	Foreign particles obstruct spinner movement, or the spinner hits the air blower cover	Check the electric wiring. Check the AB for dirt (section 5.3)
12	Shutdown due to overvoltage	Power supply voltage is above 16 V	Check voltage at XS2 connector on the heater. Check fuses, the battery, the vehicle voltage regulator, and power supply wiring
13	All attempts to start failed	Failure to ignite (after two attempts)	Check the fuel line, the fuel pump, and the air blower. Check the exhaust pipe. Check the combustion chamber, clean the opening in the plug nozzle of the combustion chamber if necessary (section 5.6)
14	Pump fault	Short or open circuit of current-conducting parts	Check for short or open circuit of the pump wiring; check the pump. Clean the pumping elements of the pump (section 5.9)

Continuation of table 2

15	Shutdown due to undervoltage	Power supply voltage is below 10 V	Check voltage at XS2 connector on the heater. Check fuses, the battery, the vehicle voltage regulator, and power supply wiring
16	Ventilation time exceeded	The flame detector is not cooled down by purging sufficiently	Check the air intake and the gas exhaust pipe. Check the flame detector; replace if necessary
17	Fuel pump fault (short circuit)	Short circuit in the fuel pump wiring	Check the fuel pump (section 5.8)
20	No communication between the control unit and the control panel	Short or open circuit in the electric wiring between the pre-heater and the control panel	Check the 5 A fuse. Check circuits and terminals (section 5.10)
21	Flame blowoff in the “WARMUP” mode	Poor conditions for combustion. Lack of fuel/air, the heat exchanger is fouled, the exhaust pipe is clogged	Check the air intake, the gas exhaust pipeline, and fuel supply, resolve the faults, and replace the fuel pump and the flame detector if necessary
22	Fuel pump fault (open circuit)	Open circuit in the fuel pump wiring	Check the fuel pump (section 5.8)
24	Rapid temperature change indicated by one of the sensors	Possible overheating near one of the temperature sensors due to poor coolant circulation	<ol style="list-style-type: none"> 1. Check the entire liquid circuit for air blocks. 2. Check the pump (section 5.9). 3. Check the overheating sensor and the temperature sensor (section 5.5). 4. Check the antifreeze for suitability at current ambient temperatures
25	The coolant is being heated up too quickly	The pre-heater goes into the cooling down mode three times in one cycle in less than 6 min	
27	Air blower fault	The motor does not rotate (movement is possibly obstructed)	Check the AB for mechanical obstruction of its rotation (section 5.3). Check the electric wiring, the air blower, and the control unit
28	Air blower fault	The motor rotates uncontrollably (possible fault in the 5 V power supply to the control unit)	
29	All ignition attempts failed with the pre-heater in operation	Ignition has been tried more than four times	Check the fuel system. Check the security of the fuel line clamps, the seal of the fuel line and the fuel pump nozzle, and the fuel pump capacity
30	Flame blowoff in the combustion chamber due to a voltage drop	The air blower stops when the vehicle voltage drops	Check the battery and wiring. (Voltage drop may be caused by long operation of the electric starter.)
37	Pre-heater is locked	Malfunction 13 appears three times in a row	Find and eliminate the cause of the malfunction. Unlock the pre-heater (section 5.11)
50	No communication between the control panel and the router	Short or open circuit in the wiring	Check the 5 A fuse. Check circuits and terminals (section 5.10)
78	Flame blowoff	Flame blowoff during operation. Information warning (not a critical fault)	Shown to inform the user. Check the security of the fuel line clamps, the seal of the fuel line and the fuel pump nozzle.

5 Purpose, repair, and replacement of pre-heater units

The main units of the heater are shown in the CPA (catalogue of parts and assemblies). BINAR-5S and BINAR-5S (diesel) pre-heaters differ in terms of control units, fuel pumps, and combustion chambers. Dismounting the heater from the vehicle and partial disassembly is required to check the condition of the heater units or to replace them.

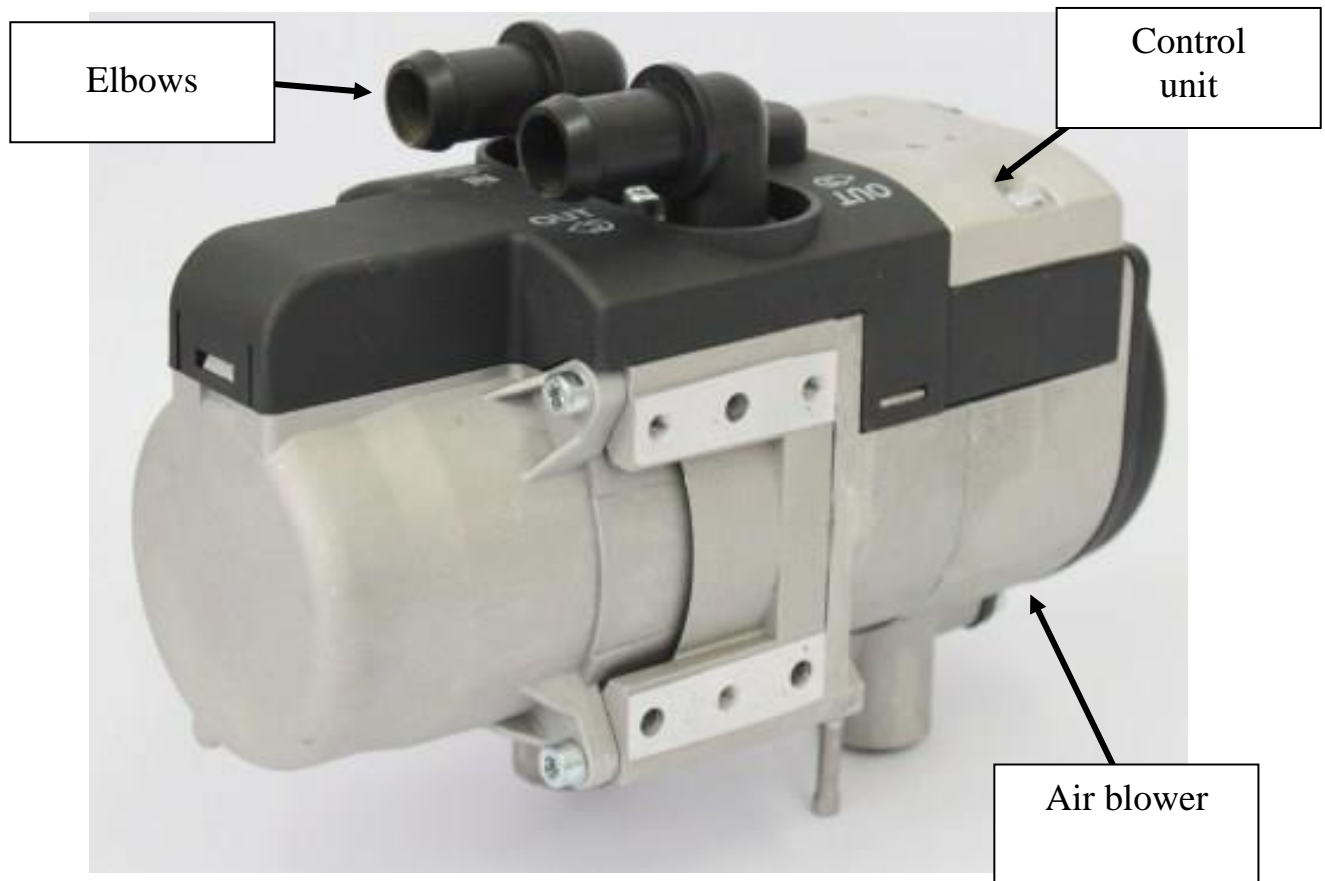

Fig. 1. Heater

Attention! To dismount the heater:

- disconnect the fuel line from the pre-heater,
- disconnect the control unit connectors from the harness,
- pinch coolant hoses with C-clamps,
- loosen and move the clamps fastening hoses to the elbows, remove the hoses,
- remove the screws fastening the heater to the mounting bracket or the screws fastening the bracket to the vehicle frame,
- dismount the heater.

5.1 *Purpose, check, and replacement of the glow plug*

The glow plug (Fig. 3) ensures ignition of the air-fuel mixture as the pre-heater starts. To check the operation of the plug and replace the plug:

- dismount the heater from the vehicle,
- remove the screw and the holddown fastening the elbows (Fig. 2),
- remove the sensor cover,
- remove the screws fastening the control unit to the air blower case, remove the control unit from the pre-heater, thus providing the required access,
- disconnect the plug outputs from the control unit,
- unscrew the plug,
- connect the plug to the CU terminals, connect the CU connectors to the harness, and turn the pre-heater on. Note whether the plug is being heated from its end and up to about the middle of the heating element. If the element starts heating up from the middle or heats all the way to the bottom, the plug is faulty and must be replaced. A lighter may be used to check the plug heating pattern. Bring a lighter to a hot plug and let out some gas. The flame must ignite instantly.

If the plug heats up poorly, check the control unit. Replace the CU with a good one. If the pre-heater works fine after this replacement, the CU removed may be deemed faulty.

If the plug does not heat up, check its operation. To do so, connect the plug to a 9 V direct current source, wait 30 s, and measure the current consumed. Note how the plug heats up.

The consumed current must be within 7–8.5 A. Continue the test for no more than 90 s. Wait no less than 180 s before repeating the test.

If the plug does not meet at least one of the above requirements, replace it. Replace the plug in the reverse order.

*** Do not use voltage above 9 V to check the plug!**

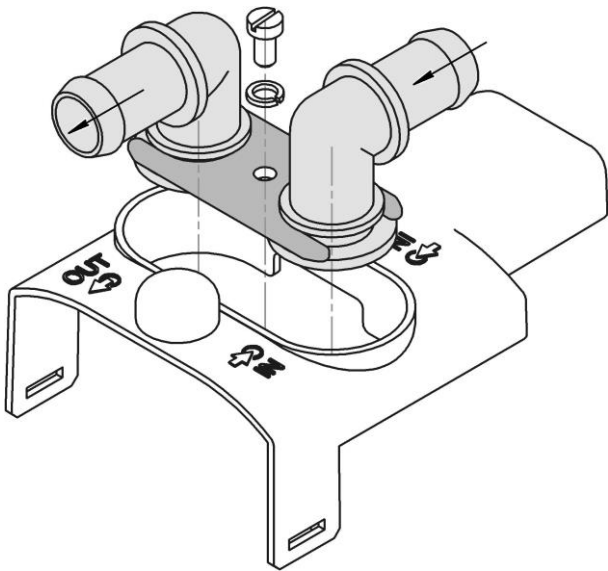

Fig. 2. Holddown dismantling

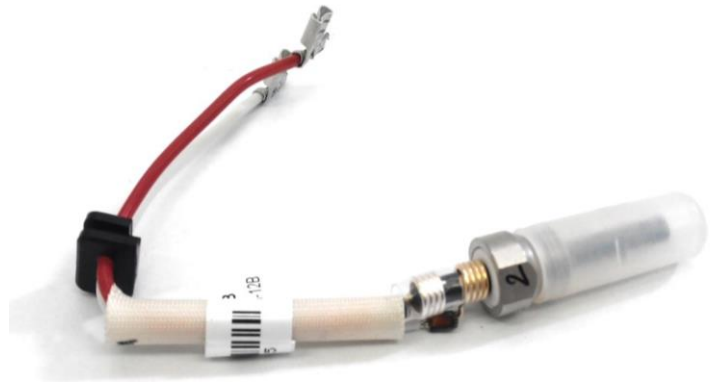

Fig. 3. Glow plug with a protective cap
(remove the cap before installing the plug in the pre-heater)

5.2 Purpose, dismantling, and replacement of the flame detector

The flame detector (Fig. 4) is used to detect flame in the combustion chamber. It is comprised of a pipe with a thermocouple with two outputs inside.

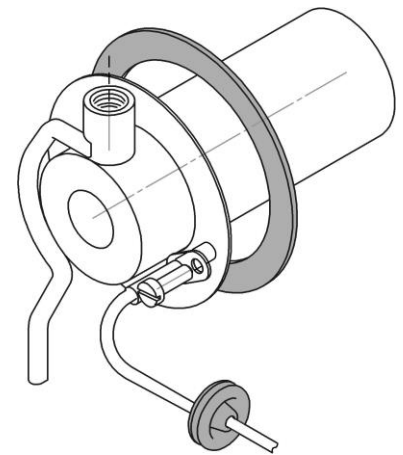

Fig. 4. Flame detector

Check the flame detector if malfunctions described in Table 2 occur.

If the fault appears during the pre-heater startup:

- dismantle the heater from the vehicle,
- remove the screws fastening the control unit to the air blower case,
- disconnect the FD terminals from the CU.

Check the resistance. The FD should indicate a short circuit or resistance no higher than 5 Ω . If the FD indicates an open circuit, it is faulty and must be replaced.

Check the insulation resistance between the outputs and the FD case. It must not be lower than 100 MΩ at 100 V. Measure the resistance at 15–35°C and relative humidity not above 80%. If the insulation resistance does not meet this criterion, replace the FD.

Check the FD channel on the control unit. Install a jumper in place of the FD (Fig. 6a). Connect the CU connectors to the harness, and turn the pre-heater on. If a malfunction code related to the FD does not appear after the pre-heater launch, the CU is fault-free. Turn the pre-heater off, disconnect the CU connectors from the harness, and remove the jumper.

Further troubleshooting involves heater disassembly. To do so:

- remove the screw and the holddown fastening the elbows,
- remove the sensor cover,
- disconnect the terminals of the temperature sensors from the CU,
- disconnect the plug and remove it together with its bushing,
- remove the screws fastening the case to the air blower (Fig. 5),
- dismount the case and the heat exchanger,
- remove the screw fastening the FD to the combustion chamber, dismount the FD.

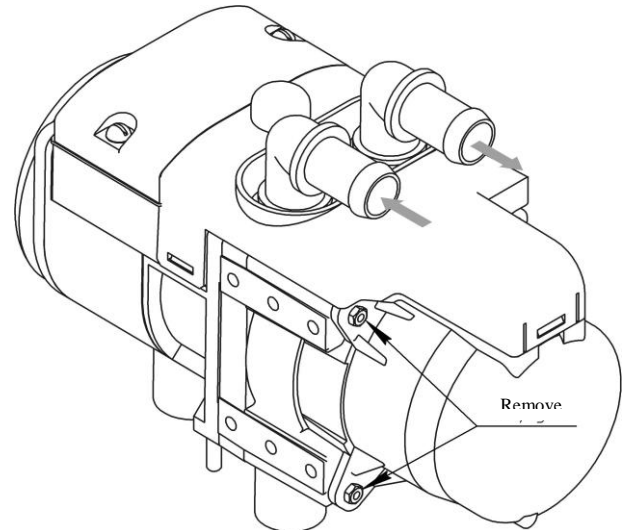

Fig. 5. Fastening of the case to the air blower

If an error appears during the pre-heater operation, either there is a crack in the weld of the FD thermocouple (i.e. the circuit is open), or the polarity of the FD connection is reversed. The fault may be revealed using two methods:

- 1) Remove the FD, connect its terminals to a multimeter (to the temperature measurement terminals), and heat up the FD, for instance, with a lighter. The temperature must increase gradually. If it increases in surges or goes down to the initial value, the FD is damaged. In this case, however, the circuit may close after the FD has cooled down.
- 2) Remove the FD, and measure the voltage at the outputs of the FD that is being heated up. When the FD case is heated up to +100°C (boiling water temperature), its outputs must provide voltage at about 3 mV. The positive pole is marked with a red tube, and the negative pole is marked with a black tube.

In case of an open circuit, the FD must be deemed faulty and should be replaced.

To check if the FD is really faulty, replace it with a good one. If the new FD does not cause the same fault, the replaced one must be deemed faulty.

Replace the FD in the reverse order.

Check the polarity of the FD connection (the wire with a black mark must be connected with the CU connector marked with a black dot, as shown in Fig. 6b).

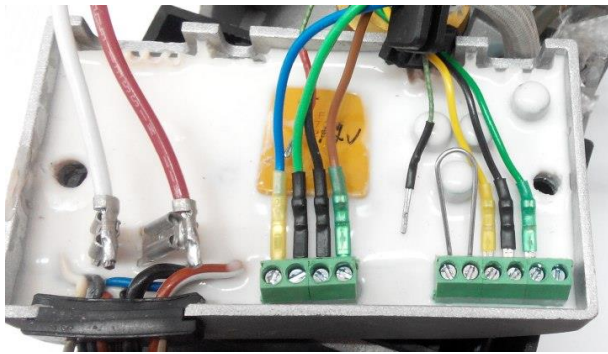

Fig. 6a. Jumper

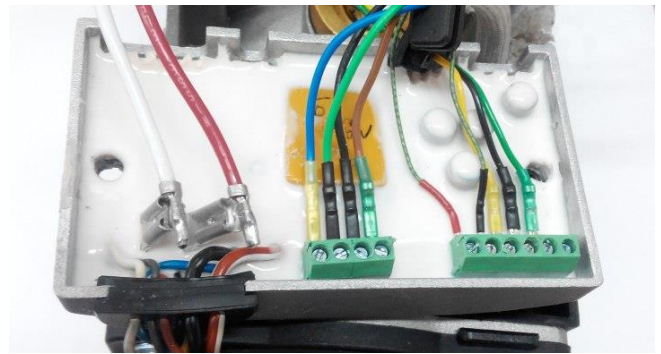

Fig. 6b

5.3 Purpose, dismounting, and replacement of the air blower

The air blower (Fig. 7) supplies air to the combustion chamber, which is necessary for combustion in every operation mode. The air flow supplied to the combustion chamber is measured by the rotation speed of a spinner inside the air blower. The rotation speed is registered by a PWM signal sent from the control unit according to a programme.

The air blower is also used for purging the combustion chamber before and after the combustion process to cool down the chamber, dehumidify it, and remove residual fuel.

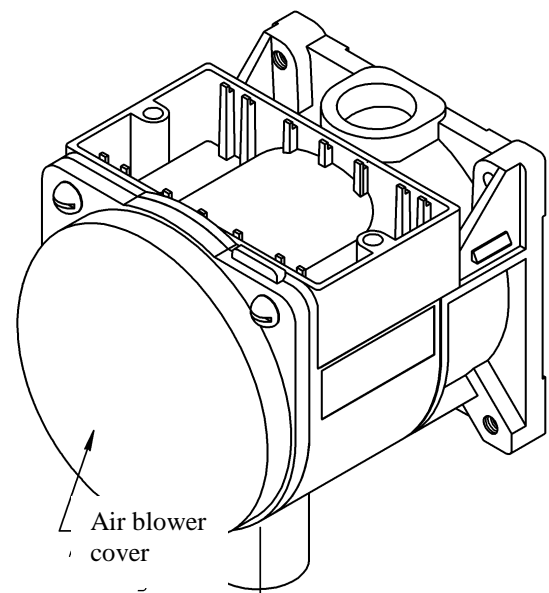

Fig. 7. Air blower

The air blower must be replaced in case of a fault in the electric motor or the spinner (this may be detected by a change of noise and low air flow).

Remove the air blower cover, and check for the presence of foreign particles on the spinner or if the scroll hits the cover during rotation. Clean the spinner of foreign particles. If the spinner hits the cover, grind the touching spots on the spinner and the cover with abrasive paper. Screw the cover in, and check whether the spinner hits the cover once again.

If the air blower does not rotate, check its operation. Check the security of the connection of the air blower to the control unit. Connect the CU connectors to the harness. Connect the blue wire terminal to the black wire terminal for a short time, as shown in Fig. 8. The AB must gradually speed up and just as gradually slow down as soon as the terminals are disconnected.

Where the AB must be replaced, dismantle it in the following order:

- dismantle the heater from the vehicle,
- remove the screws fastening the control unit to the air blower case,
- disconnect the FD and AB terminals from the CU,
- remove the screw and the holddown fastening the elbows,
- remove the sensor cover,
- disconnect the plug and remove it together with its bushing,
- remove the screws fastening the case to the air blower,
- dismantle the case and the heat exchanger,
- dismantle the combustion chamber with the FD.



Fig. 8.
Connection example

Mount the air blower in the reverse order.

5.4 Purpose, dismantling, and replacement of the control unit

The control unit (Fig. 9) is installed onto the air blower and is used for automatic control of the pre-heater operation. It also provides diagnostics and monitoring of pre-heater units during operation.

During troubleshooting of the control unit, first ensure all parts of the pre-heater are in working order, and then check the fuse. If the fuse is fault-free as well, replace the control unit. If the pre-heater with a new control unit works fine, the one removed must be deemed faulty and should be replaced.

To dismantle the control unit:

- dismantle the heater from the vehicle,
- remove the screws fastening the control unit to the air blower case,
- disconnect all wiring terminals from the CU,
- dismantle the CU.

Reinstall the control unit in the reverse order.

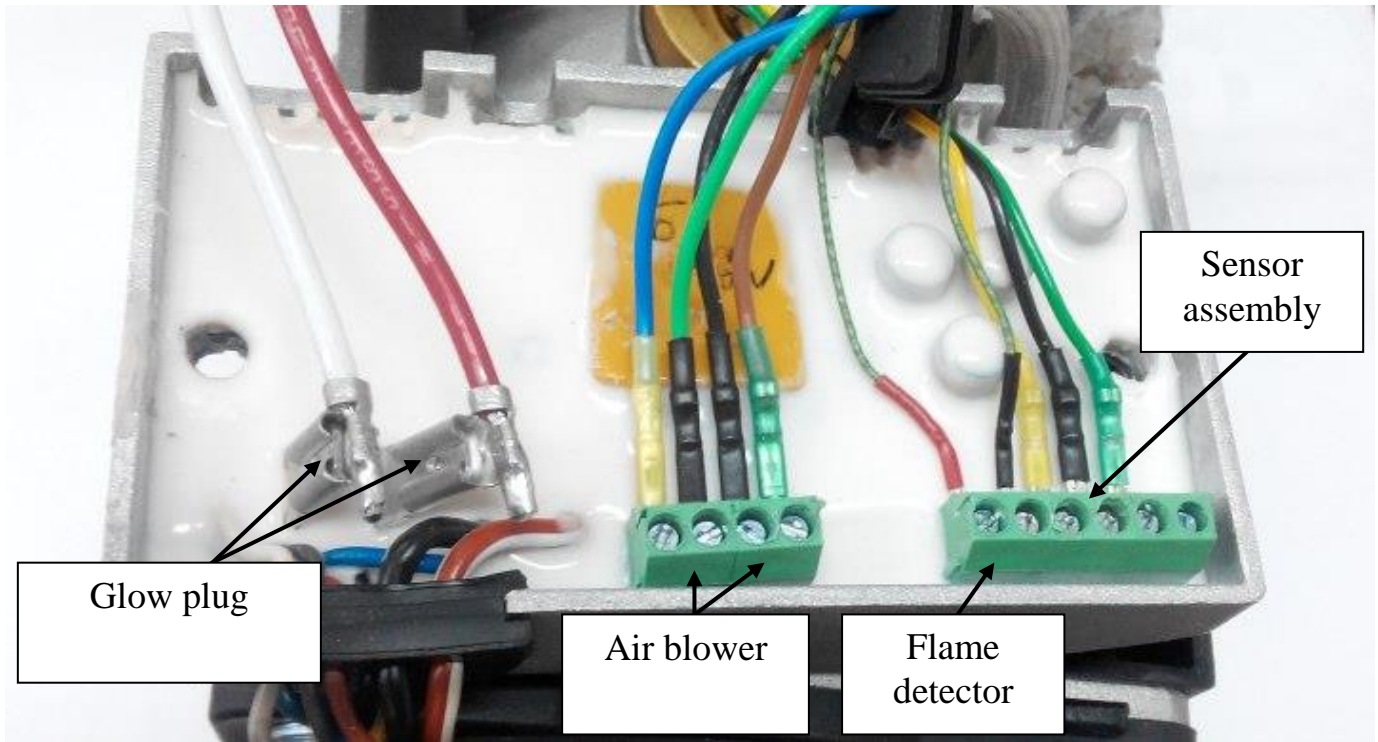

Fig. 9. Control unit

5.5 Purpose, dismounting, and replacement of the temperature sensors

The temperature and overheating sensors are installed within one assembly (Fig. 10). The sensors monitor the temperatures of heated liquid and the heat exchanger. Both sensors are identical chips mounted in a metal case.



Fig. 10. Sensor assembly

To check the sensors, partially disassemble the heater first.

- dismount the heater from the vehicle,
- remove the screws fastening the control unit to the air blower case,
- disconnect the sensor assembly terminals from the CU.

Check the output voltage of the sensors. At 0°C, the output voltage is 2.73 V. At higher temperatures, the output voltage is also higher: every 1°C increase in temperature corresponds to 0.01 V increase at the sensor output.

It is recommended that you measure the voltage with the coolant at ambient temperature.

Compare the sensor readings with the actual liquid temperature. In case of short circuit or if the readings from a sensor do not match actual coolant temperature, this sensor must be deemed faulty and should be replaced.

Continue to dismount in the following order:

- remove the screw and the holddown fastening the elbows,
- remove the sensor cover,
- loosen the screw fastening the sensor holddown,
- dismount the sensors.

Reinstall the sensors in the reverse order. Connect the sensors as shown in Fig. 9.

5.6 *Purpose, dismounting, and replacement of the combustion chamber*

The combustion chamber (Fig. 11) is used for creating and burning the air-fuel mixture. A throttling wire is installed in the fuel (petrol) pipe of the combustion chamber in order to increase the fuel head. Symptoms of combustion chamber faults are:

- a failure to start the pre-heater (provided other parts are fault-free), a burnt-out case or inner parts of the chamber,
- a high (above 500°C) temperature of the exhaust gases,
- low heat capacity.

Visually inspect the combustion chamber. To do so, first partially disassemble the heater (as described in section 5.2).

Where visual inspection reveals burnt-out parts or spots on the case, replace the combustion chamber.

Visually inspect the plug nozzle and the air intake opening. If the opening is clogged, clean it.

A glow plug screen is installed to equalise fuel supply to the combustion chamber. Where the screen is fouled or clogged, replace it.

The screen must be installed fully tensioned. Where it is installed without having complete contact with the end face, the pre-heater may fail to launch. **Do not use the plug bushing to push the screen into the combustion chamber nozzle!**

Install the combustion chamber in the reverse order. A new gasket or the O-rings may need to be replaced (see CPA). Visually inspect the heat exchanger as described in section 5.7 as well.



Fig. 11. Combustion chamber



Fig. 11a. Diesel version



Fig. 11b. Petrol version

5.7 Purpose, dismounting, and replacement of the heat exchanger

The heat exchanger (Fig. 12) is used to transfer heat from the hot gas flow generated as a result of combustion of the air-fuel mixture to the coolant circulating in the liquid jacket of the heater.

One fault that may appear during heat exchanger operation is loss of seal. Its symptoms are grumbling or explosive noises of burning caused by the entry of coolant into the gas-air line.

Dismount the heat exchanger as described in section 5.2.



Fig. 12. Heat exchanger

Before installing the heat exchanger, loosen the sensor holddown.

After installing the heat exchanger and tightening the screws, fasten the sensor holddown, and check the seal of the heater liquid circuit with compressed air at 0.25 MPa (2.5 kgf/cm²). Supply compressed air for five minutes. No air pressure drop must be observed.

5.8 Purpose, dismounting, and replacement of the fuel pump

The fuel pump (Fig. 13) is used for metered fuel supply to the combustion chamber.



Fig. 13. Fuel pump

Possible fuel pump faults:

- a) fuel is not supplied to the fuel pipe of the heater during launch, and a characteristic knocking noise from the fuel pump is absent,
- b) the fuel pump operates, but no fuel is supplied to the fuel pipe of the pre-heater,
- c) combustion stops when the pre-heater is switched to the “max.” operation mode, which means the fuel pump does not provide the required capacity.

To repair faults and determine the capacity of the fuel pump:

- before troubleshooting, first check the presence and quality of fuel in the tank,
- check the condition of the wiring and connectors,
- check whether the fuel pump launches during the pre-heater startup and emits the characteristic noise of the piston moving inside the pump,
- check the seal of the fuel line over its entire length from the tank to the fuel pump and from the fuel pump to the heater.

You may dismount the fuel pump and shake it to release the piston jammed inside the pump after long storage or failure to observe the preventive maintenance specified in the operating manual.

In case of fault in a Thomas Magnete fuel pump, it must be replaced.

5.9 Purpose, dismounting, and replacement of the electric motor and the pump

The electric motor and the pump (Fig. 14, Fig.14a) are used to circulate coolant across the vehicle engine/cabin heating systems.

The pump may fail to operate for the following reasons:

- poor coolant quality (frozen coolant),
- foreign particles inside the liquid circuit,
- short or open circuit in the electric wiring,
- wear on the working parts of the pump.



Fig. 14. Electric motor and the pump for pre-heater 12V



Fig. 14a. Electric motor and the pump for pre-heater 24V

If the coolant is frozen (has turned into a snow-like mass) inside the pump, the pump may continue to operate but will not be able to circulate any coolant. Unfreeze the pump, and replace the coolant with that of better quality.

Where there are foreign particles (such as fine chippings or sawdust) inside the liquid circuit, they may obstruct pump operation. A clear symptom of a contaminated pump is poor circulation of the coolant. To clean the pump, partially disassemble it in the following order:

- remove the pump from the vehicle,
- remove the four screws, and remove the cover,
- clean the cover and the spinner of foreign particles,
- reinstall the cover, and check the pump operation.

If the pump does not turn on, check the wiring. If the wiring is not visibly damaged, connect an electric source at the pump operating voltage directly to the pump terminals for a short period. If the pump starts, it is fault-free. Check the wiring with a multimeter.

5.10 Purpose, dismounting, and replacement of the control panel

The control panel (Fig. 14, “panel”) provides manual control of the pre-heater. The complete list of control panel functions is specified in the operating manual for the panel.

To check whether the control panel is faulty, check the wire terminal blocks.



Fig. 14. Control panel

If the check does not reveal any faults, but the control panel still does not operate, replace the control panel with a new one. If the new control panel does not cause the same fault, the replaced one must be deemed faulty.

To dismount the control panel:

- disconnect the panel connector from the harness connector,
- remove the panel from its mounting bracket.

Reinstall the control panel in the reverse order. If the panel is fault-free, but the pre-heater still fails to start, check the wiring in the harness and the CU.

5.11 Unlocking the pre-heater

Where malfunction 13 appears three times in a row during the pre-heater launch, the pre-heater will be locked. In this case, malfunction code 37 is displayed on the control panel during launch.

Before unlocking, visually inspect the pre-heater body for damage.

Connect the pre-heater to the battery*, launch the pre-heater, and wait for malfunction code 37 to appear. After the code is displayed, disconnect power to the pre-heater within 20 s either by disconnecting it from the battery or by removing the 25 A fuse.

***Attention!** After the pre-heater is connected to the battery, the control panel communicates with the control unit. The pre-heater must be started only after communication is established (current time or 0:00 appears on the screen).

Repeat this procedure three times.

If you fail to disconnect the pre-heater within 20 s of startup, repeat the procedure from the beginning. For this reason, it is recommended to use two people for this procedure.

After disconnecting the pre-heater three times, it will be unlocked.

6 Pre-heater check after installation

When the pre-heater is installed on a vehicle after repair, it must be checked for correct operation with and without the vehicle engine running.

Connect the pre-heater to the harness, the fuel line, and the liquid circuit. Remove air from the fuel system and the liquid circuit.

Using the control panel, set the pre-heater operation duration to 20 min. Start the pre-heater. Check whether the pre-heater operates correctly in every mode displayed on the panel (for more information on operation modes, see the operating manual for the panel).

Check the pre-heater for abnormal noises during operation. Check the security of the clamps (no coolant leaks are allowed).

Where a fault occurs during the pre-heater launch or operation, and the pre-heater switches off, a malfunction code will appear on the control panel. Repair the fault and repeat the test.

7 Manufacturer's warranty

- 7.1. The manufacturer's warranty is only valid if the user observes the rules for operation of the pre-heater specified in the operating manual.
- 7.2. Every pre-heater repaired by a company authorised by the manufacturer must have an entry in the warranty certificate indicating a description of the maintenance, the replacement of units and parts and bearing a stamp of the organisation performing the maintenance.
- 7.3. Warranty does not apply to the control panel, the control unit, the heater, and the fuel pump with evidences of repair attempts.